

FilterFlow Automatic Water Boilers

www.filterflow.co.uk



Pure Quality



QUALITY GUARANTEED
You can choose Lincat products with confidence. All products in this leaflet are backed by the reassurance of a comprehensive UK twelve months parts and labour warranty (except filter cartridges).



**Lincat Limited, Whisby Road,
Lincoln LN6 3QZ,
United Kingdom**

UK Sales Tel: 01522 875500 UK Spares Tel: 01522 875510 UK General Tel: 01522 875555
UK Fax: 01522 875530 International Sales Tel: +44 1522 503250 International Fax: +44 1522 875530
Website: www.lincat.co.uk UK Sales e-mail: sales@lincat.co.uk International Sales e-mail: export@lincat.co.uk



Filtered hot water on tap

Around the world we drink countless millions of cups of tea and coffee each and every day. The consumer's seemingly insatiable demand for tea and coffee drives sales of many other food products too. So the ability to make hot beverages quickly, efficiently and economically around the clock is essential. From the smallest cafés to the busiest restaurants and the largest hotels, from the factory canteen to the humble office kitchen, all catering establishments need to have a reliable supply of piping hot water on tap every day!

Permanently plumbed to the mains water supply, the new range of FilterFlow automatic water boilers from Lincat will not only ensure you keep the hot drinks coming, they provide the finest quality filtered water for your customers and staff.

A better choice, pure and simple

- Unique built-in filtration ensures premium water quality and reduced scale build-up
- Reduced limescale means higher energy efficiency and lower running costs
- Low-cost, easy-fit replacement filter cartridges
- Lower maintenance and energy costs
- High hourly output – ideal even in busy establishments
- Reliable electronic control system
- Stylish contemporary design – ideal for front-of-house
- Advanced diagnostics with LCD panel showing operational status

WRAS
APPROVED
PRODUCT

Built-in filtration fitted as standard

Manufactured to the highest standards, FilterFlow automatic water boilers combine style, function, reliability and value for money with a pioneering new development in water boiler filtration.

A water filter is essential, not only in hard water areas to reduce problematic scale build-up, but also to remove impurities that can leave an unpleasant taste. Until now, these filters have always been plumbed in as a separate unit. This is unattractive and adds cost. FilterFlow is ingeniously different. It revolutionises water boiler design by incorporating the filter cartridge within the boiler casing.

Give your customers the taste of quality

FilterFlow boilers ensure that water is always of the highest quality. Their advanced filtration system produces a real improvement, even to beverages made with soft water, by reducing sediment and other impurities, as well as the taste and odour of chlorine. Drinks not only taste better, they look better too.

You can give your customers a visible assurance of water purity and beverage quality by affixing the branded FilterFlow badge to your water boiler. This is supplied as standard with all FilterFlow models.



Convenient, easy-change filters

No need to call out an engineer to replace the filter unit. With FilterFlow, changing the filter cartridge is as easy as changing a light bulb. Just slide the cartridge into its housing and turn to lock it into position. Job done!

High hourly output - low energy input

A high performance machine, FilterFlow is ideal for busy establishments. The EB3F model for example can deliver 31 litres of piping hot water every hour, the highest output from any 3kW water boiler on the market.

Better still, FilterFlow water boilers don't thirst for energy! The heating element is controlled by a highly accurate electronic temperature management system. Coupled with effective insulation, economic operation is assured. During 'stand by' periods, power consumption per hour is just 100 watts. So your FilterFlow boiler can be left on at all times, ensuring that piping hot water is always on tap.

FilterFlow saves you money in other ways too

FilterFlow water boilers not only eliminate the need for costly separate filtration installations, they save you energy too! Even a 1.6mm coating of limescale on a heating element can make it up to 12% less efficient. So, by substantially reducing calcium carbonate content, the cause of scale build-up in hard water areas, you can significantly reduce energy consumption. And you save on service and downtime costs!

With a long working life of around 3,000 litres, FilterFlow cartridges offer exceptional value for money and replacement costs are surprisingly low.

Sleek, clean, fully integrated design

No separate filter unit. No unsightly exposed pipework. With its sleek, stylish profile and attractive stainless steel back, FilterFlow water boilers are ideal for front-of-house applications.



Reliable and responsive electronic control systems

Water boilers are constantly in use, so reliability is important. FilterFlow boilers utilise the latest technology to ensure peak performance, day in, day out. Internal level sensors detect the volume of water in the boiler and control replenishment at a rate that avoids excessive falls in water temperature. Reliable and responsive electronic control maintains water temperature within very close tolerances. This means that the water is always held at the correct 'near boiling point' temperature.

Designed for easy maintenance

Routine maintenance of your FilterFlow automatic water boiler couldn't be easier. Access to all internal components is gained simply by removing the lid and front panel. FilterFlow boilers require much less descaling, but when this is required, the process is quick and straightforward – and there's no need to move the boiler from its normal position.

LCD panel keeps you informed

An advanced diagnostics system, complete with an LCD panel, keeps you informed of the boiler's status at all times. As well as advising you when water heating is in progress, and when water has reached the correct temperature, the display will alert you when the filter needs changing and when descaling is required. In the unlikely event of a breakdown, the diagnostics will advise you of the likely cause. The display will also inform you of other faults, such as an interruption to the water supply.



A model to meet your needs

The FilterFlow range offers you a choice of four automatic water boilers with outputs ranging from 31 litres to 60 litres per hour. Each model is supplied with an integral

drip tray as standard – an accessory often only available as an optional extra from other manufacturers.

Inclusive Accessories

- First filter cartridge
- Drip tray
- Water feed hose

Optional Accessories

- **BR49** - Wall mounting kit for EB3F and EB4F
- **BR50** - Wall mounting kit for EB6F and EB6TF
- **FC02** - Replacement filter cartridge

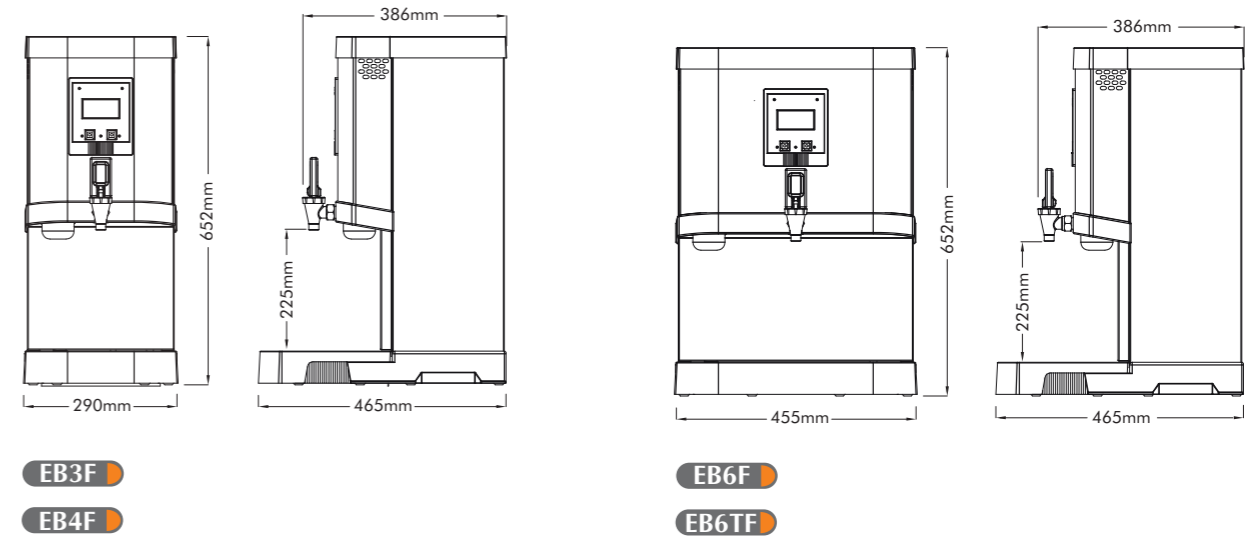

Technical Specifications

Model	EB3F	EB4F	EB6F	EB6TF
Dimensions				
H x W x D (mm)	652 x 290 x 465	652 x 290 x 465	652 x 455 x 465	652 x 455 x 465
Power Rating (kW)	3.0	4.5	6.0	6.0
Standby power consumption (kW/hr)*	0.1	0.1	0.1	0.1
Output per hour	31 litres 55 pints 205 cups	45 litres 79 pints 300 cups	60 litres 105 pints 400 cups	60 litres 105 pints 400 cups
Rapid draw off	9 litres 16 pints 60 cups	9 litres 16 pints 60 cups	17 litres 30 pints 110 cups	17 litres 30 pints 110 cups
Recovery per minute	0.52 litres 0.92 pints	0.75 litres 1.32 pints	1.00 litres 1.76 pints	1.00 litres 1.76 pints
Boiling time**	26 mins	19 mins	23 mins	23 mins
Single phase current @ 230V (1N~+⊕)				
amps per phase	13	20	26	26
Three phase current @ 400V (3N~+⊕)				
amps per phase	N/A	N/A	13/13/0	13/13/0

* The approximate power consumption when the boiler is full and to temperature. This is the typical consumption during periods of non-use, such as overnight.

** Boiling time is the time to heat to full capacity from empty.